



VeloCens™ 3-T



ITEM	DESCRIPTION
# Simultaneous Tests	3
Dimensions	When display is fully open (LW x H): 40.64cm (16") x 22.86cm (9") x 24.13cm (9.5") When the display is closed (H): 11.43cm (4.5")
Weight	4.20kgs (9.25lbs)
Detection Level (<i>E. coli</i> & <i>Total Coliform</i>)	1 CFU/100 ml
Material	Anodized Aluminum
Input Voltage	9-18 VDC
Input Power	35.5 W
Lifetime	7-10 years
Standards Alignment	IP66
Touchscreen	29.46cm (11.6") Capacitive Touchscreen (Resolution: 1920 x 1080)
Internet Connectivity	Both Wifi and LAN



VeloCens™ 5-T



ITEM	DESCRIPTION
# Simultaneous Tests	5
Dimensions	When display is fully open (LWH): 60.96cm (24") x 22.86cm (9") x 24.13cm (9.5") When the display is closed (H): 11.43cm (4.5")
Weight	4.54kgs (10lbs)
Detection Level (<i>E. coli</i> & <i>Total Coliform</i>)	1 CFU/100 ml
Material	Anodized Aluminum
Input Voltage	9-18 VDC
Input Power	35.5 W
Lifetime	7-10 years
Standards Alignment	IP66
Touchscreen	29.46cm (11.6") Capacitive Touchscreen (Resolution: 1920 x 1080)
Internet Connectivity	Both Wifi and LAN



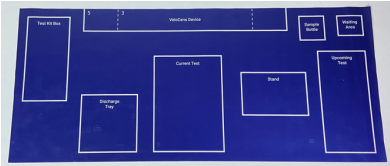
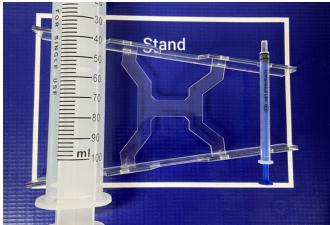

Setup Components

SETUP COMPONENTS	DESCRIPTION
<p>Carrying Case</p> 	<p>The device and test kit supplies are shipped and stored in this case.</p> <p>Dimensions: 82.5cm (32.5") x 53.3cm (21") x 31.2cm (12.28")</p> <p>Weight: 13kg (28.6lbs)</p>
<p>Mat</p> 	<p>Set up the equipment and supplies on the mat in pre-labelled spots.</p> <p>Dimensions: 47cm (18.5") x 104.1cm (41")</p>
<p>Syringe Holder</p> 	<p>During the preparation stage, large and small syringes are placed on the holder to ensure they are not contaminated during handling.</p> <p>Dimensions: 20cm (7.9") x 10cm (3.9") x 4cm (1.6")</p>



Test Kit Components

Replacement Test Kit supplies for the VeloCens™ unit are ordered in groups of 10 and stored on-site. Used Test Kits are returned to Roshan Water™ for recycle and reuse.

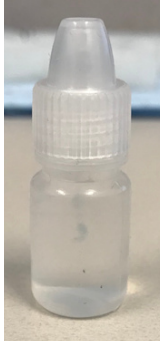
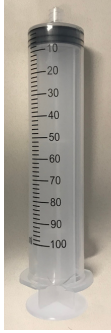
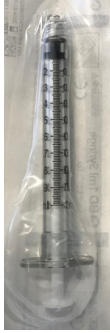
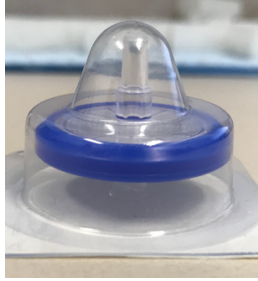
Test Kit Components	
<p>Test Kit Box Dimensions (LWH): 22.9cm (9") x 10.2cm (4") x 7.6cm (3")</p> 	<p>Water Sample Collection Bottle (x1)</p> <p>*Bottles have sealed caps and contain sodium thiosulfate to remove any residual chlorines in the sample.</p> 
<p>Test Cartridge (x2) - One for E.coli - One for Total Coliform</p> 	<p>Eyedropper (x2) - One contains Solution B-E - One contains Solution B-T</p> 
<p>Large Syringe (x2)</p> 	<p>Small Syringe (x2)</p> 
<p>Syringe Filter (x2)</p> 	<p>Vial (x2) - One contains Solution A-E - One contains Solution A-T</p> 